

New



the
orford
group

technology that works
"Evolution" EB45R-Sn
Revolutionising Refrigeration Today

All Purpose Display & Storage Refrigerator

Full height Internal LED
"Twin" spread lighting

Dual magnet door
sealing and plastic
fascia, thermal break

Ducted air flow system
for even temperature
distribution

EMS controller using
"smart memory
functions" automatically
saving you energy.

Easy access condenser
Filter

Easy roll lockable
castors



High Energy Efficiency

**Outstanding
Energy Efficiency**

Brilliant LED Sign Panel

Automated and
Manual
Lighting control

Self closing
toughened safety
glass doors, double
low E , Argon filled,
incorporating the
latest warm edge
technology

Full Length Easy Grip
Door Handle

Door sensor
controlled fan

"Shhhh" whisper
quiet operation
utilising patented
EBM Evap and
Condenser fan motors
adding, efficiency
and unparalleled
reliability to the new
Evolution models.

Evolution is an **Easy Clip** fully removable, universal,
refrigeration package (one package fits all models).

Proudly Australian Designed

by The Orford Group

IP protected by AUS DSN no 345317



With Evolution comes much responsibility. The Orford Group continues to develop World Class Energy reduction systems to improve the lives of our customers and future generations.

1300 ORFORD (1300 673 673)
+617 4641 7372
sales@theorfordgroup.com.au
www.theorfordgroup.com.au

PO Box 18120
Clifford Gardens
Queensland 4350
Australia



"Evolution" EB45R-Sn

Three Door Vertical Display Refrigerator

Features

E World class,

- Design
- Energy Efficiency
- Performance
- Quality
- Reliability

E Universal Refrigeration Package

- One package fits the entire EB Range
- Cassette Style: Removable without tools
- Minimal training required for

non-qualified personal to replace the package

E Energy Management System (EMS)

- Automatically learns you trading times
- Automates your energy savings
- Perishable and non-perishable mode

E Lighting Control

- Automated or manual control, you choose
- Independent switching of interior and sign lighting

E Condenser Fan Function

- Your choice of reversing or non-reversing function

E Condenser Filter

- Easy Access filter: No tools, no covers to remove



High Energy Efficiency

EB45R-Sn	Vertical Display Refrigerator with Illuminated Advertising Sign
Specifications	
Construction	Powder Coated galvanized steel Interior / Exterior White
Capacity	1384 Litres (Gross)
Dimensions	1460W x 762D x 2220H
Weight	265 Kg
Operating Temp	0° - 5° C.
Ambient Temp Range	0° - 40° C.
Power Point	220 - 240v 50Hz. (Standard GPO)
Input Current	3.2 Amps
Thermometer	Digital
Shelves	12 Height Adjustable Heavy Duty PVC Coated
Shelves	3 Fixed Stainless Steel Base Shelves
Shelf Adjustment	12mm Increments
Refrigerated Shelf Area	3.38 m ²
Condensate Disposal	Automatic by energy efficient, No Cost, Hot Gas
Door	3 x Self Closing, Double Glazed Safety Glass, Double Heat reflective Low E, Warm edge
Footings	Heavy Duty Castors, Lockable Front
Interior Light	LED, Automatic and manual control
Refrigerant	R134a
Drier	Solid Core
Insulation	50mm Polyurethane, CFC, HCFC, HFC Free
Cabinet Classes	3M1, 4M1, 5M1
MEPS	Compliant (High Efficiency)
* Energy Consumption	6.03 kWh/24h
Condenser Filter	Easy front access
Illuminated Advertising Sign	200mm High, Top Mounted
Sign Illumination	LED, Automatic and manual control

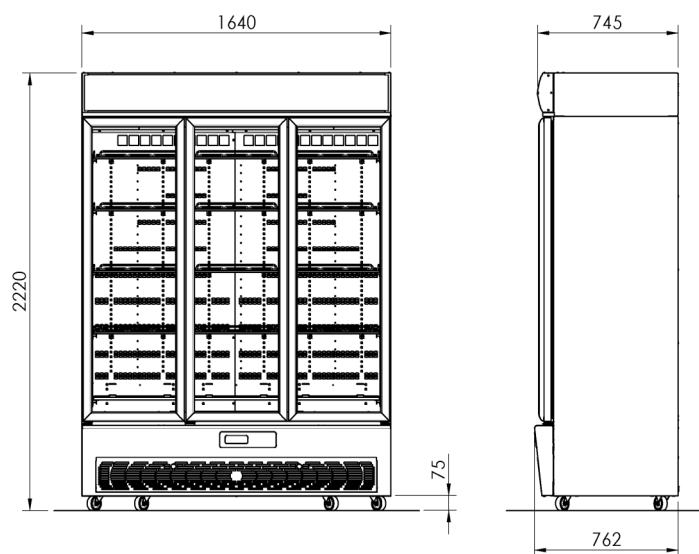
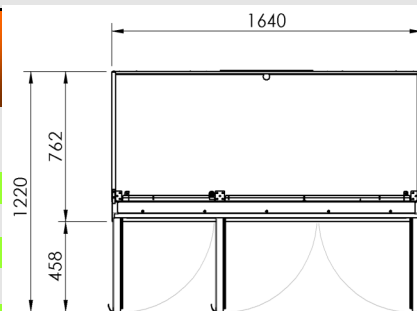

* Energy Consumption measured at 25°C. Cabinet Class 3M1 as per Australian Standard AS1731